

MT-TSD-...

time relays



- **Star-Delta start-up with independently controlled times T1 and T2 (1 time function; 7 time ranges)**
- Cadmium - free contacts • AC/DC input voltages
- Cover - installation module, width 17,5 mm
- Direct mounting on 35 mm rail mount acc. to PN-EN 60715
- Application: in low-voltage systems
- Compliance with standard PN-EN 61812-1
- Recognitions, certifications, directives: **CE ENEC**

Output circuits - contact data

Number and type of contacts		2 x 1 CO	
Contact material		AgSnO₂	
Max. switching voltage		400 V AC / 300 V DC	
Rated load	AC1	10 A / 250 V AC	
	DC1	10 A / 24 V DC; 0,3 A / 250 V DC	
Rated current		10 A / 250 V AC	
Max. breaking capacity	AC1	16 A / 250 V AC	
Min. breaking capacity		0,3 W 5 V, 5 mA	
Contact resistance		≤ 100 mΩ	
Max. operating frequency			
• at rated load	AC1	600 cycles/hour	
Input circuit			
Rated voltage	AC: 50/60 Hz AC/DC	12...240 V	terminals (+)A1 – (-)A2
Operating range of supply voltage		0,9...1,1 U _n	
Rated power consumption	AC	≤ 4,5 VA AC: 50 Hz	
	DC	≤ 1,5 W	
Range of supply frequency	AC	48...63 Hz	
Insulation according to PN-EN 60664-1			
Insulation rated voltage		250 V AC	
Rated surge voltage		2 500 V 1,2 / 50 μs	
Overvoltage category		II	
Insulation pollution degree		1	
Flammability degree		V-0 UL94	
Dielectric strength	• input - outputs	2 500 V AC	type of insulation: basic
	• contact clearance	1 000 V AC	type of clearance: micro-disconnection
General data			
Electrical life	• resistive AC1	> 0,5 x 10 ⁵	10 A, 250 V AC
Mechanical life (cycles)		> 3 x 10 ⁷	
Dimensions (L x W x H)		90 ① x 17,5 x 63,5 mm	
Weight		84 g	
Ambient temperature	• storage	-40...+70 °C	
	• operating	-20...+45 °C	
Cover protection category		IP 20	PN-EN 60529
Relative humidity		up to 85%	
Shock resistance		15 g	
Vibration resistance		0,35 mm 10...55 Hz	
Time module data			
Functions		SD	
Time ranges (start-up for the star) T1		10 s; 30 s; 1 min.; 3 min.; 10 min.; 30 min.; 1 h	
Timing adjustment T1		smooth - (0,05...1) x time range	
Transit time (adjustable) ② T2		smoothly within the range 0,05...1 s (linear adjustment of time)	
Setting accuracy		± 5% ③	
Repeatability		± 3%	
Values affecting the timing adjustment	• temperature	± 0,05% / °C	
	• humidity	± 0,05% / %HR	
Recovery time		≤ 50 ms	
LED indicator		green LED U ON - indication of supply voltage U green LED U flashing - measurement of T1 and T2 times yellow LEDs ON/OFF - contactors switching signal	

① Length with 35 mm rail taps: 98,8 mm.

② Pause time between switching off the star contactor and switching on the delta contactor.

③ Calculated from the final range values, for the setting direction from minimum to maximum.

MT-TSD-...

time relays

Time functions

SD - Star-Delta start-up.

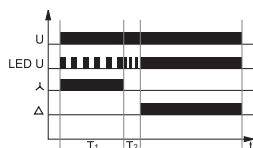

When the supply voltage U is applied, the operating star-contact (15-18) becomes closed, which is signaled with illumination of the yellow LED. Measurement of the set time T1 starts, and the green LED flashes at 500 ms. After the T1 time has lapsed, the star contact is disconnected and the relay begins measuring the T2 time, which is signaled with the green LED flashing at 250 ms. After the T2 time has lapsed, the delta contact (25-28) is switched on together with the yellow LED, and the green LED remains illuminated.

U - supply voltage; T1, T2 - measured times; t - time axis

Additional functions

Supply diode: it is lit permanently when the time is not being measured. In course of the T1 time measurement, it flashes at 500 ms period where it is lit for 80% of the time, and off for 20% of the time. For the T2 time, the period is 250 ms.

Adjustment of the set values: the values of time and range are read in the course of the relay's operation. The set values may be modified at any moment.

Release: the relay is released with the supply voltage.

Supply: the relay may be supplied with DC voltage or AC voltage 48...63 Hz of 10,8...250 V. A programmed control of the supply voltage has been applied so the processor shall not start operation if the voltage is lower than approximately 10 V. The supply voltage is permanently monitored in course of the operation of the relay. When the voltage drops below 9 V for more than 50 ms, the relay shall be reset. Owing to this, the regeneration time is programmed to 50 ms, and it does not depend on the tolerance of the elements.

Dimensions

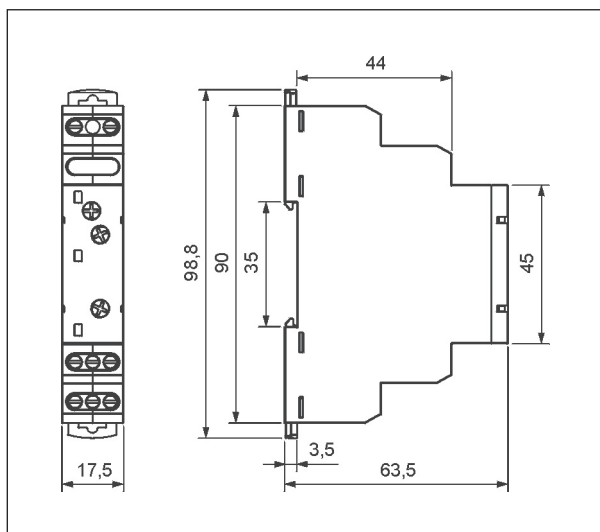

Front panel description

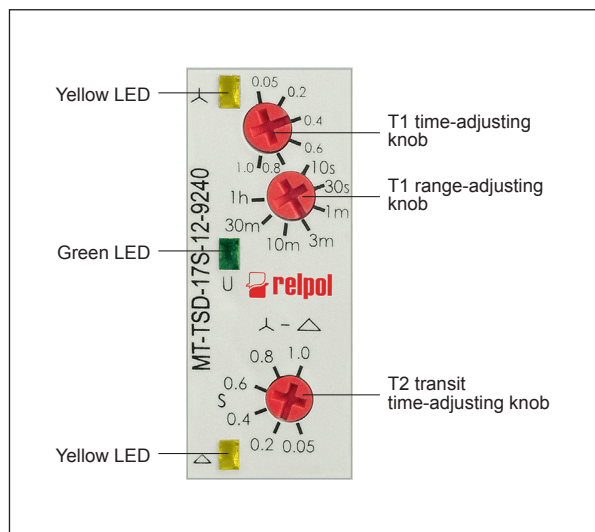

Connection diagram

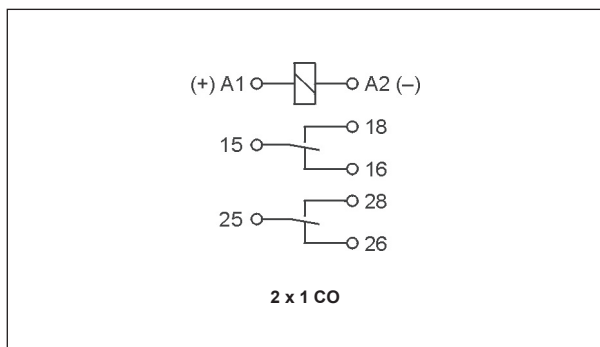

Mounting

Relays **MT-TSD-...** are designed for direct mounting on 35 mm rail mount acc. to PN-EN 60715. Operational position - any. **Connections:** max. cross section of the cables: 1 x 2,5 mm² / 2 x 1,5 mm² (1 x 14 / 2 x 16 AWG), length of the cable deinsulation: 6,5 mm, max. tightening moment for the terminal: 0,6 Nm.



Two taps:
easy assembly on 35 mm rail,
firm tapping (top and bottom).

Ordering codes

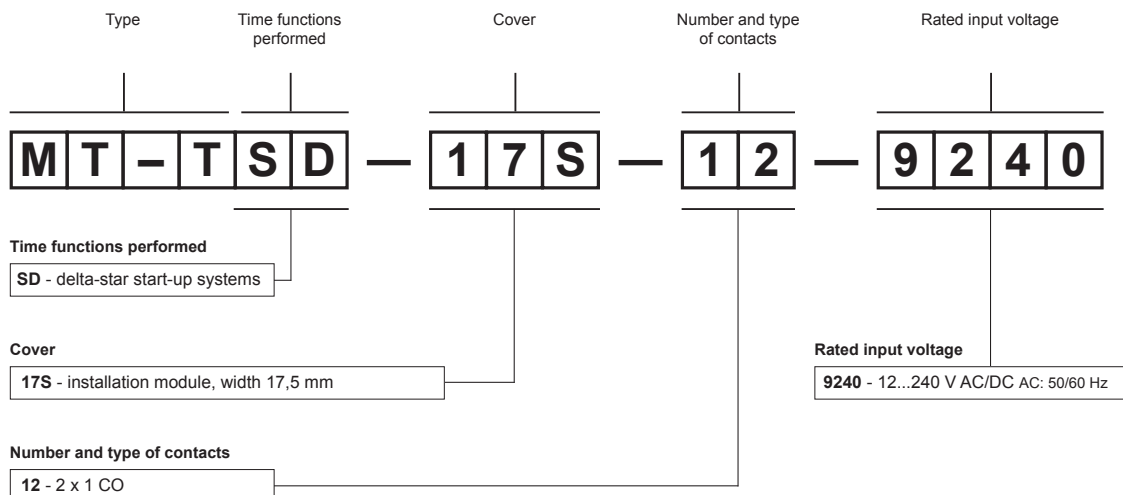

Example of ordering code:

MT-TSD-17S-12-9240

time relay **MT-TSD-...**, single-function (relay perform function SD), cover - installation module, width 17,5 mm, one changeover contact, contact material AgSnO₂, rated input voltage 12...240 V AC/DC AC: 50/60 Hz

PRECAUTIONS:

1. Ensure that the parameters of the product described in its specification provide a safety margin for the appropriate operation of the device or system and never use the product in circumstances which exceed the parameters of the product. 2. Never touch any live parts of the device. 3. Ensure that the product has been connected correctly. An incorrect connection may cause malfunction, excessive heating or risk of fire. 4. In case of any risk of any serious material loss or death or injuries of humans or animals, the devices or systems shall be designed so to equip them with double safety system to guarantee their reliable operation.