



R2M

miniature industrial relays



- Relays of general application
- For plug-in sockets: 35 mm rail mount acc. to PN-EN 60715; on panel mounting
- For PCB and for soldering connections
- AC and DC coils
- Recognitions, certifications, directives: RoHS,   

Contact data

Number and type of contacts		2 CO
Contact material		AgNi , AgNi/Au 0,2 µm, AgSnO ₂
Rated / max. switching voltage	AC	250 V / 250 V
Min. switching voltage		5 V AgNi, 5 V AgNi/Au 0,2 µm, 10 V AgSnO ₂
Rated load	AC1	5 A / 250 V AC
	DC1	5 A / 24 V DC
Min. switching current		5 mA AgNi, 5 mA AgNi/Au 0,2 µm, 10 mA AgSnO ₂
Rated current		5 A
Max. breaking capacity	AC1	1 250 VA
Min. breaking capacity		0,3 W AgNi, 0,3 W AgNi/Au 0,2 µm, 1 W AgSnO ₂
Contact resistance		≤ 100 mΩ
Max. operating frequency		
• at rated load	AC1	1 200 cycles/hour
• no load		36 000 cycles/hour

Coil data

Rated voltage	50/60 Hz AC	6 ... 240 V
	DC	6 ... 110 V
Must release voltage		≥ 0,05 U _n
Operating range of supply voltage		see Tables 1, 2
Rated power consumption	AC	1,2 VA
	DC	0,9 W

Insulation according to PN-EN 60664-1

Insulation rated voltage		250 V AC
Rated surge voltage		2 500 V 1,2 / 50 µs
Overvoltage category		II
Insulation pollution degree		3
Dielectric strength		
• between coil and contacts		2 000 V AC type of insulation: basic
• contact clearance		1 000 V AC type of clearance: micro-disconnection
• pole - pole		2 000 V AC type of insulation: basic
Contact - coil distance		
• clearance		≥ 3 mm
• creepage		≥ 4 mm

General data

Operating / release time (typical values)		AC: 8 ms / 7 ms	DC: 10 ms / 3 ms
Electrical life			
• resistive AC1		> 2 x 10 ⁵	5 A, 250 V AC
• cosφ		see Fig. 2	
Mechanical life (cycles)		> 10 ⁷	
Dimensions (L x W x H)		27,5 x 14 x 32,9 mm	
Weight		22 g	
Ambient temperature	• storage	-40...+70 °C	
	• operating	-40...+55 °C	
Cover protection category		IP 40	PN-EN 60529
Shock resistance		10 g	
Vibration resistance		5 g 10...150 Hz	
Solder bath temperature		max. 270 °C	
Soldering time		max. 5 s	

The data in bold type pertain to the standard versions of the relays.

Note: relays with AgNi contacts can be used up to 5 A at resistive and inductive load.

Coil data - DC voltage version

Table 1

Coil code	Rated voltage V DC	Coil resistance at 20 °C Ω	Acceptable resistance	Coil operating range V DC	
				min. (at 20 °C)	max. (at 55 °C)
1006	6	47	$\pm 10\%$	4,8	6,6
1012	12	188	$\pm 10\%$	9,6	13,2
1024	24	750	$\pm 10\%$	19,2	26,4
1048	48	2 660	$\pm 10\%$	38,4	52,8
1060	60	4 000	$\pm 10\%$	48,0	66,0
1080	80	7 100	$\pm 10\%$	64,0	88,0
1110	110	13 480	$\pm 10\%$	88,0	121,0

The data in bold type pertain to the standard versions of the relays.

Coil data - AC 50/60 Hz voltage version

Table 2

Coil code	Rated voltage V AC	Coil resistance at 20 °C Ω	Acceptable resistance	Coil operating range V AC	
				min. (at 20 °C)	max. (at 55 °C)
5006	6	16	$\pm 10\%$	4,8	6,6
5012	12	68	$\pm 10\%$	9,6	13,2
5024	24	270	$\pm 10\%$	19,2	26,4
5050	50	1 150	$\pm 10\%$	40,0	55,0
5100	100	5 590	$\pm 10\%$	80,0	110,0
5110	110	5 670	$\pm 10\%$	88,0	121,0
5115	115	5 990	$\pm 10\%$	92,0	126,0
5120	120	6 390	$\pm 10\%$	96,0	132,0
5220	220	21 470	$\pm 10\%$	176,0	242,0
5230	230	21 470	$\pm 10\%$	184,0	253,0
5240	240	25 390	$\pm 10\%$	192,0	264,0

The data in bold type pertain to the standard versions of the relays.

Dimensions - plug-in version

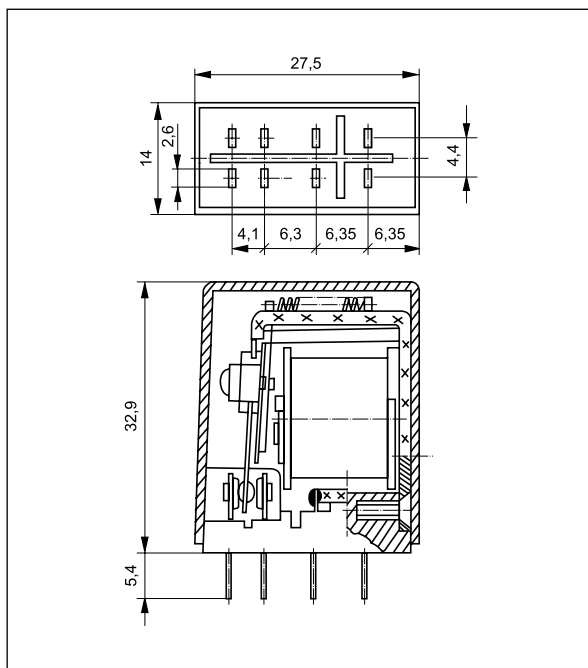

Dimensions - PCB version

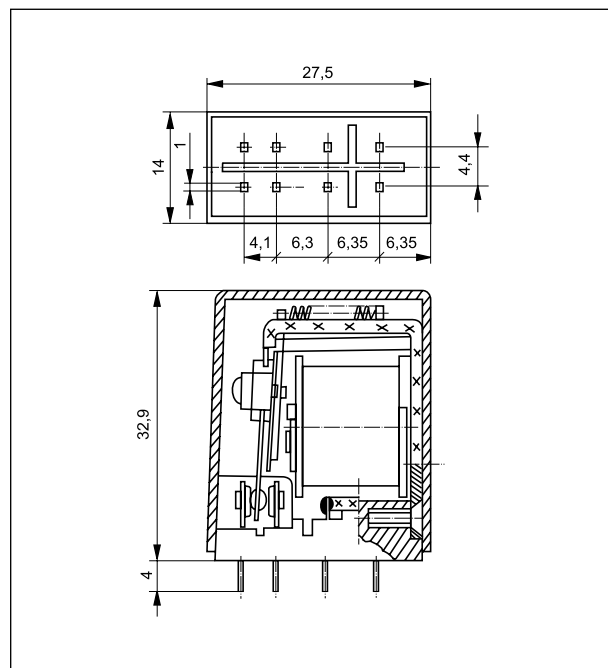

Connection diagram (pin side view)

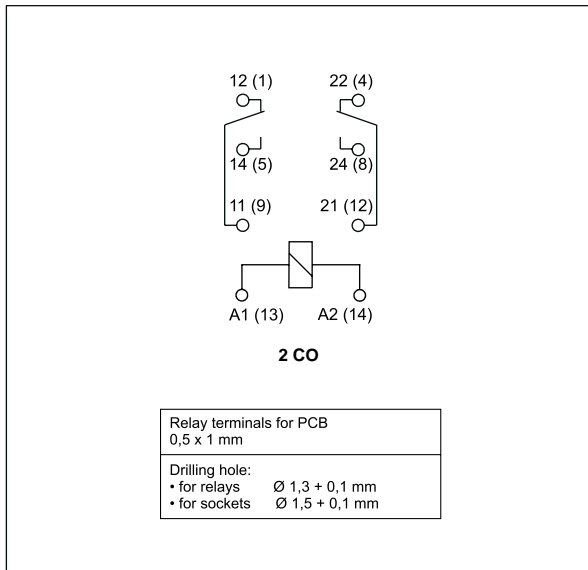

Electrical life at AC resistive load.
Switching frequency: 1 200 cycles/hour

Fig. 1

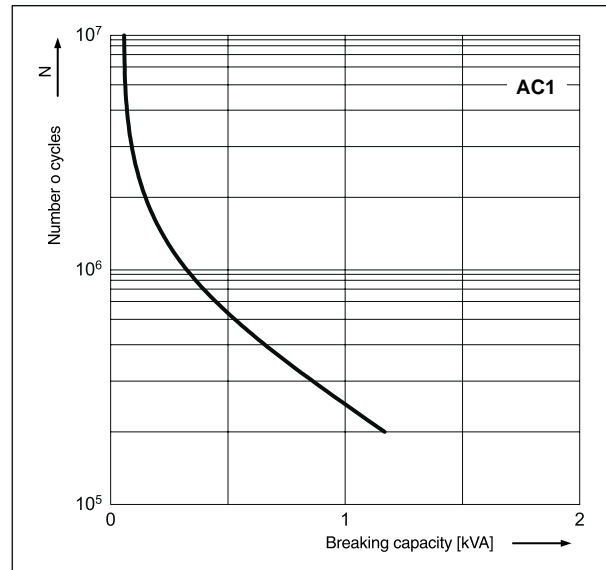

Electrical life reduction factor at AC inductive load

Fig. 2

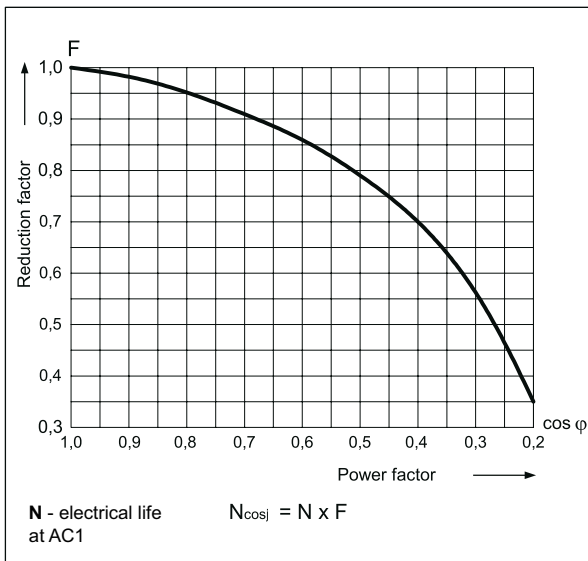

Max. DC resistive load breaking capacity

Fig. 3

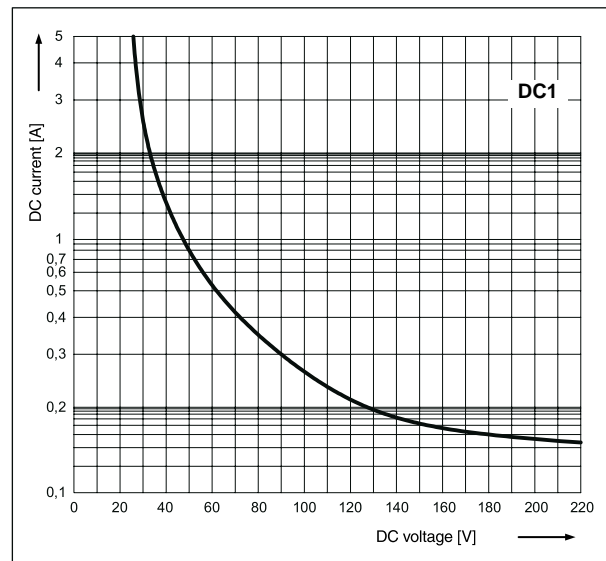

Mounting

Relays **R2M** are designed for: • screw terminals plug-in sockets **GZ2** with clip **GZ2 1060** and spring clamp **GZ2 1111**, 35 mm rail mount acc. to PN-EN 60715 or on panel mounting with two M3 screws • plug-in sockets for PCB mounting **S2M** with clip **G4 1050** • solder terminals sockets **G2M** with clip **G4 1050** and spring clamp **G2M 1020** • direct PCB mounting.

Contact material selection for different load types

- **AgNi** - for resistive or inductive loads,
- **AgNi/Au 0,2 µm** - Au protects the contact surface during storage,
- **AgSnO₂** - for capacitive loads or incandescent lamp loads.

Ordering codes

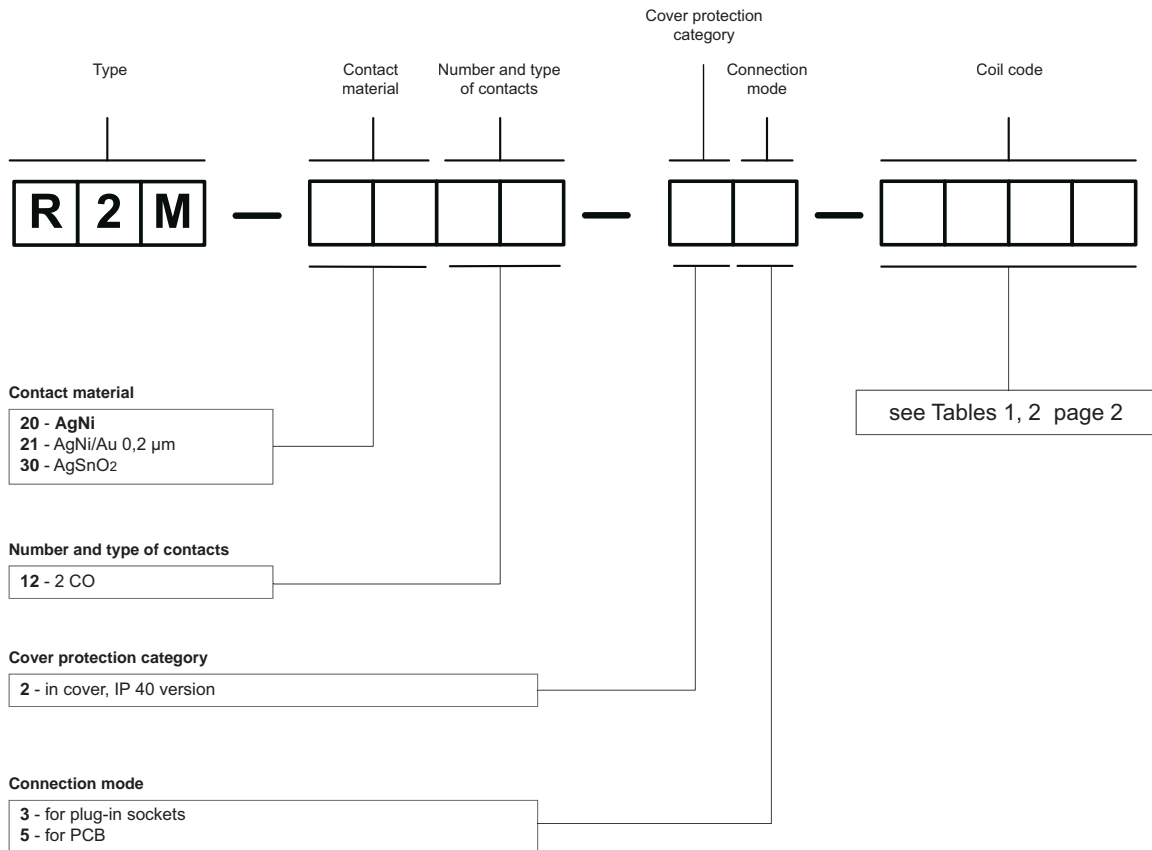

Examples of ordering codes:

R2M-2012-23-5230 relay **R2M**, for plug-in sockets, two changeover contacts, contact material AgNi, coil voltage 230 V AC 50/60 Hz, in cover IP 40

R2M-2012-25-1024 relay **R2M**, for PCB, two changeover contacts, contact material AgNi, coil voltage 24 V DC, in cover IP 40

PIR2M

Interface relay:
 relay R2M
 and socket GZ2
 - see www.repol.com.pl



Plug-in sockets and accessories

GZ2

For R2M

Screw terminals
 Max. tightening moment
 for the terminal: 0,7 Nm
 35 mm rail mount
 acc. to PN-EN 60715
 or on panel mounting
 65,2 x 20 x 25 mm
 Two poles
 7 A, 250 V AC



Connection diagram

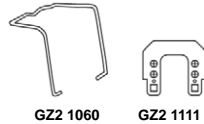
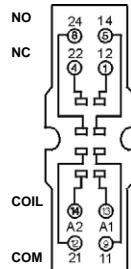

Accessories

Dimensions

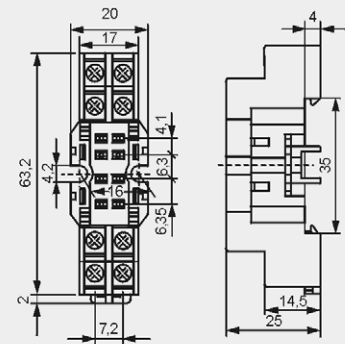

S2M

For R2M

For PCB
 29,6 x 14 x 10,5 mm
 Two poles
 5 A, 250 V AC



Pinout

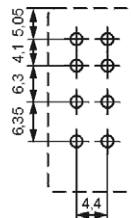

Accessories

Dimensions

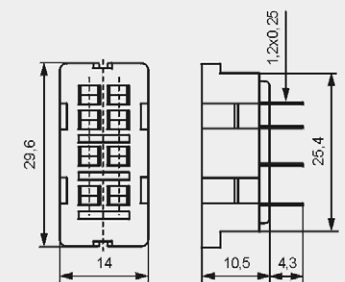

G2M

For R2M

Solder terminals
 40,5 x 14 x 10,5 mm
 Two poles
 5 A, 250 V AC

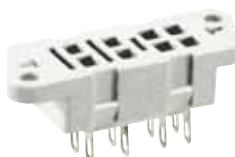

Accessories

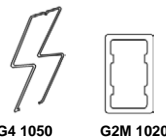

Dimensions

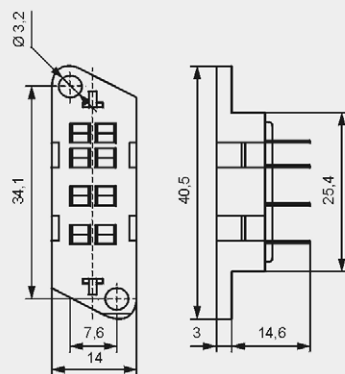

PRECAUTIONS:

1. Ensure that the parameters of the product described in its specification provide a safety margin for the appropriate operation of the device or system and never use the product in circumstances which exceed the parameters of the product. 2. Never touch any live parts of the device. 3. Ensure that the product has been connected correctly. An incorrect connection may cause malfunction, excessive heating or risk of fire. 4. In case of any risk of any serious material loss or death or injuries of humans or animals, the devices or systems shall be designed so to equip them with double safety system to guarantee their reliable operation.