

RSM954

subminiature signal relays



- Subminiature, monostable relays
- Small dimensions
- **DC coils of up to 24 V DC**, low coil power 0,36 W
- Sealed, for wave soldering and cleaning
- Applications: for telecommunication devices, office equipment, industrial control, etc.
- Recognitions, certifications, directives: RoHS, 

Contact data

Number and type of contacts		1 CO
Contact material		Ag/Au 0,2 μm
Rated / max. switching voltage	AC	120 V / 120 V
Min. switching voltage		5 V
Rated load	AC1	3 A / 120 V AC
	DC1	3 A / 24 V DC
Min. switching current		10 mA
Rated current		3 A
Max. breaking capacity	AC1	360 VA
Min. breaking capacity		50 mW
Contact resistance		≤ 100 mΩ

Coil data

Rated voltage	DC	3 ... 24 V
Must release voltage		DC: ≥ 0,05 U _n
Operating range of supply voltage		see Table 1
Rated power consumption	DC	0,36 W

Insulation according to PN-EN 60664-1

Dielectric strength			
• between coil and contacts		500 V AC	type of insulation: basic
• contact clearance		500 V AC	type of clearance: micro-disconnection
Contact - coil distance			
• clearance		≥ 1,2 mm	
• creepage		≥ 2 mm	

General data

Operating / release time (typical values)		8 ms / 4 ms	
Electrical life (number of cycles)			
• resistive AC1	1 800 cycles/hour	> 10 ⁵	3 A, 120 V AC
• resistive DC1	1 800 cycles/hour	> 10 ⁵	3 A, 24 V DC
Mechanical life	18 000 cycles/hour	> 10 ⁷	
Dimensions (L x W x H)		15,4 x 10,4 x 11,4 mm	
Weight		3,5 g	
Ambient temperature	• operating	-25...+55 °C	
Cover protection category		IP 64	PN-EN 60529
Shock resistance		10 g	
Vibration resistance		1,5 mm DA (constant amplitude)	10...55 Hz
Solder bath temperature		max. 235 °C	
Soldering time		max. 3,5 s	

The data in bold type pertain to the standard versions of the relays.

RSM954

subminiature signal relays

Coil data - DC voltage version, sensitive

Table 1

Coil code	Rated voltage V DC	Coil resistance at 20 °C Ω	Acceptable resistance	Coil operating range V DC	
				min. (at 20 °C)	max. (at 20 °C)
1003	3	25	$\pm 10\%$	2,25	3,9
1005	5	69	$\pm 10\%$	3,75	6,5
1006	6	100	$\pm 10\%$	4,50	7,8
1009	9	225	$\pm 10\%$	6,75	11,7
1012	12	400	$\pm 10\%$	9,00	15,6
1024	24	1 600	$\pm 10\%$	18,00	31,2

Dimensions

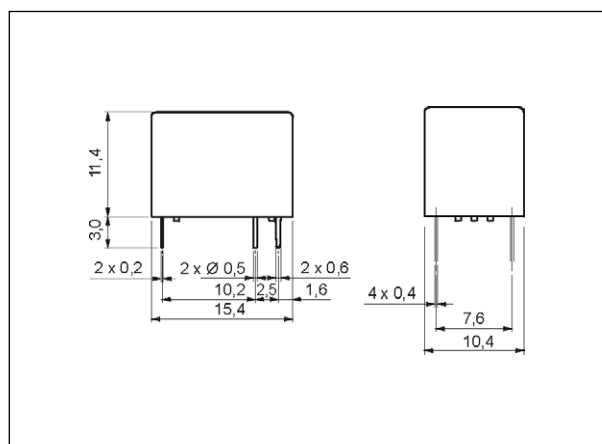

Connection diagram (pin side view)

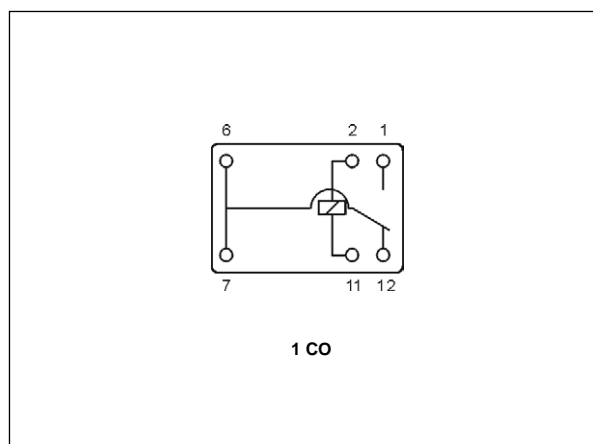

Coil temperature rise

Fig. 1

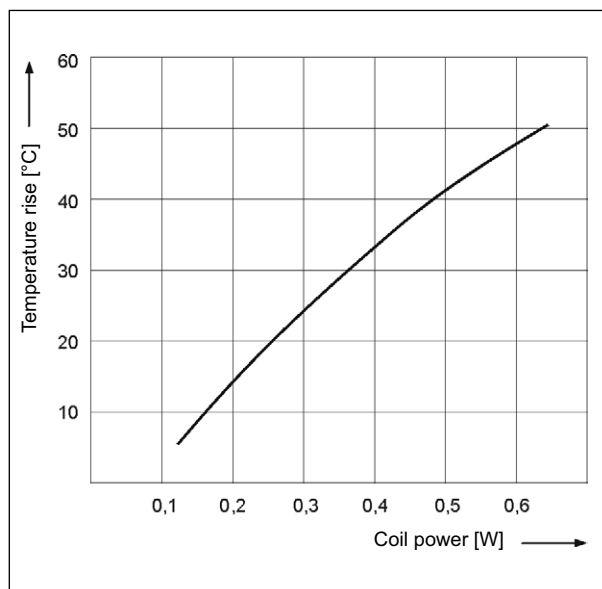

Operating / release time

Fig. 2

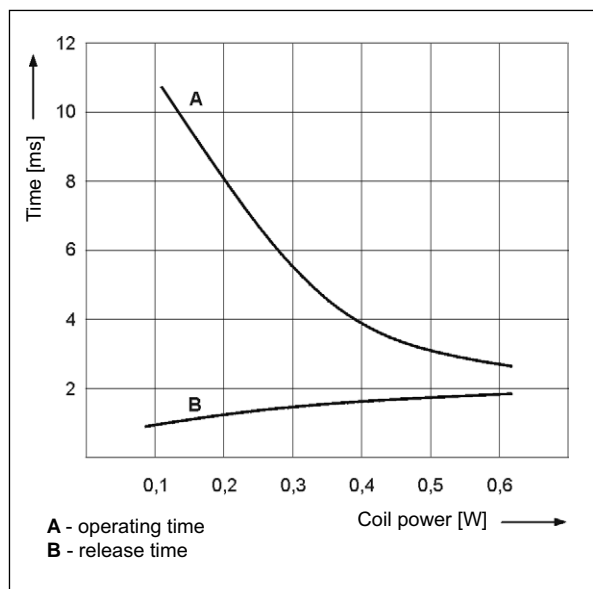

Electrical life

Fig. 3

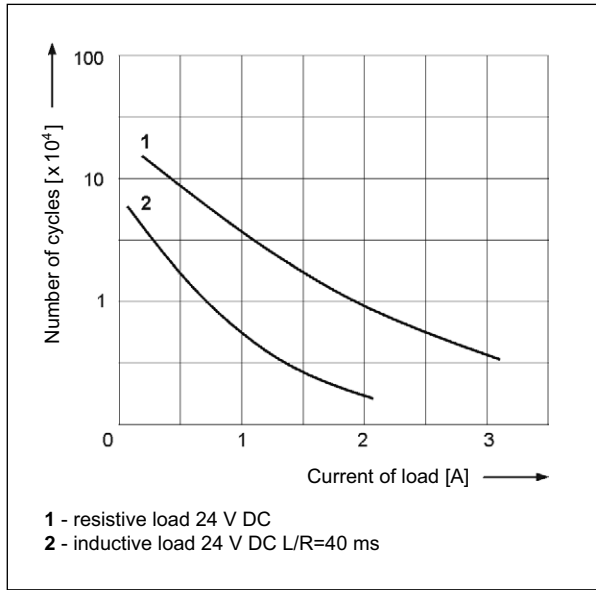

Pinout (solder side view)

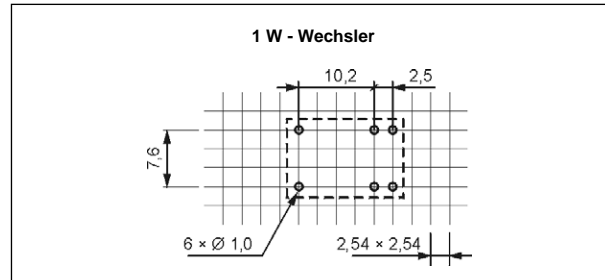

Mounting

Relays **RSM954** are designed for direct PCB mounting.

Ordering codes

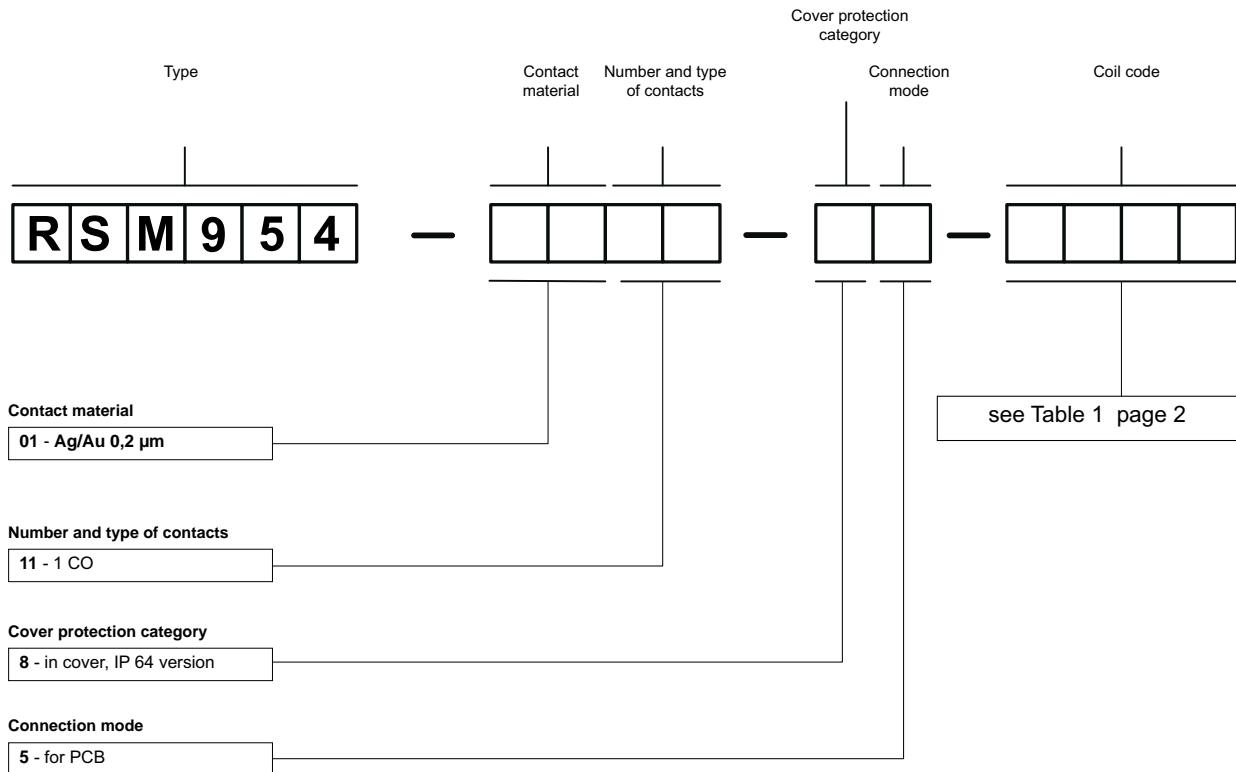

Example of ordering code:

RSM954-0111-85-1005

relay **RSM954**, for PCB, one changeover contact, contact material Ag/Au 0,2 μ m, coil voltage 5 V DC, in cover IP 64

PRECAUTIONS:

1. Ensure that the parameters of the product described in its specification provide a safety margin for the appropriate operation of the device or system and never use the product in circumstances which exceed the parameters of the product. 2. Never touch any live parts of the device. 3. Ensure that the product has been connected correctly. An incorrect connection may cause malfunction, excessive heating or risk of fire. 4. In case of any risk of any serious material loss or death or injuries of humans or animals, the devices or systems shall be designed so to equip them with double safety system to guarantee their reliable operation.