

RUC





industrial relays of small dimensions





with adaptor (V)

with adaptor (H)

• Power relays of general application • AC and DC coils • Mounting: in sockets; 35 mm rail mount acc. to PN-EN 60715; on panel; PCB • Versions: faston 187 (4,8 x 0,5 mm); faston 250 (6,3 x 0,8 mm) • 3 mm contact gap (option - only in versions with normally open contacts) • Additional features: K - test button; L - light indicator (LED) • Applications: control of electromagnets; systems of heating, cooling, ventilation, air conditioning; control with single-phase and three-phase motors; catering industry machines and equipment; automation systems; photoelectric systems; etc.

• Recognitions, certifications, directives: RoHS,     

Contact data

Number and type of contacts		2 CO, 3 CO, 2 NO, 3 NO	2 NO, 3 NO with contact gap \geq 3 mm
Contact material		AgCdO , AgNi	
Rated / max. switching voltage	AC	400 V / 440 V	230 V / 250 V 
Min. switching voltage		5 V AgNi, 10 V AgCdO	
Rated load	AC1 DC1	16 A / 250 V AC or 10 A / 400 V AC	16 A / 250 V AC 
Min. switching current		5 mA AgNi, 10 mA AgCdO	
Max. inrush current		40 A	
Rated current		16 A	
Max. breaking capacity	AC1	4 000 VA	
Min. breaking capacity		0,3 W AgNi, 1 W AgCdO	
Contact resistance		\leq 100 m Ω	
Max. operating frequency			
• at rated load	AC1	1 200 cykli/h	
• no load		12 000 cykli/h	





Coil data





Rated voltage	AC DC	6 ... 240 V 50/60 Hz	400 V 50 Hz 
Must release voltage		AC: \geq 0,15 U_n	DC: \geq 0,1 U_n
Operating range of supply voltage		see Tables 1, 2, 3, 4	
Rated power consumption	AC DC	2,8 VA 50 Hz	2,5 VA 60 Hz 1,7 W with contact gap \geq 3 mm

Insulation according to PN-EN 60664-1

Insulation rated voltage		400 V AC	
Rated surge voltage		4 000 V 1,2 / 50 μ s	
Overvoltage category		III	
Insulation pollution degree		2	
Dielectric strength	• between coil and contacts	2 500 V AC	type of insulation: basic
	• contact clearance	1 500 V AC	type of clearance: micro-disconnection
	• pole - pole	2 500 V AC	with contact gap \geq 3 mm, type of clearance: full-disconnection
		2 500 V AC	type of insulation: basic
Contact - coil distance	• clearance	\geq 5 mm 2 CO, 2 NO	\geq 4 mm 3 CO, 3 NO
	• creepage	\geq 8 mm 2 CO, 2 NO	\geq 5 mm 3 CO, 3 NO

General data

Operating / release time (typical values)		20 ms / 15 ms	
Electrical life	• resistive AC1 • $\cos\phi$	$>$ 10^5 16 A, 250 V AC	$>$ 10^5 10 A, 400 V AC
Mechanical life (cycles)		$>$ 10^7	
Motor load according to UL 508		2 CO: 0,33 HP 120 V AC, single-phase motor 0,5 HP 240 V AC, single-phase motor 3 CO: 0,33 HP 120 V AC, single-phase motor 0,5 HP 240 V AC, single-phase motor 3 CO: 0,5 HP 240 V AC, three-phase motor	
Dimensions (L x W x H)		RUC faston 4,8 x 0,5 	RUC faston 6,3 x 0,8 
Weight		80 g 	85 g 
Ambient temperature	• storage • operating	-40...+85 $^{\circ}$ C	
		AC: -40...+55 $^{\circ}$ C 3 CO, 3 NO / 16 A	(+70 $^{\circ}$ C 2 CO, 2 NO / 16 A)
		DC: -40...+55 $^{\circ}$ C 3 CO, 3 NO / 16 A	(+70 $^{\circ}$ C 3 CO, 3 NO / 10 A; 2 CO, 2 NO / 16 A)
Cover protection category		IP 00	PN-EN 60529
Shock / vibration resistance		10 g / 5 g	10...150 Hz
Solder bath temperature		max. 270 $^{\circ}$ C	
Soldering time		max. 5 s	

The data in bold type pertain to the standard versions of the relays.  For RUC faston 4,8 x 0,5 with GUC11 socket, max. switching voltages and coil voltages of relays are limited to 250 V AC / DC.  For plug-in sockets version: 36,1 x 38,6 x 45,5 mm. For version: with (V) adaptor: 58,75 x 38,6 x 45,9 mm; with (H) adaptor: 46,8 x 38,6 x 62,45 mm. For version with mounting flange: 66,3 x 38,6 x 36,1 mm. For PCB version: 36,1 x 38,6 x 52,5 mm.  For version: with (V) adaptor: 62,4 x 38,6 x 45,9 mm; with (H) adaptor: 46,8 x 38,6 x 66,1 mm. For version with mounting flange: 66,3 x 38,6 x 36,1 mm.  Weight of plug-in sockets version and PCB version (RUC faston 4,8 x 0,5).  Weight of version with (V) or (H) adaptor, and version with mounting flange.

Coil data - DC voltage version
Table 1

Coil code	Rated voltage V DC	Coil resistance at 20 °C Ω	Acceptable resistance	Coil operating range V DC	
				min. (at 20 °C)	max. (at 55 °C)
1006	6	28	± 10%	4,8	6,6
1012	12	110	± 10%	9,6	13,2
1024	24	430	± 10%	19,2	26,4
1042	42	1 340	± 10%	33,6	46,2
1048	48	1 750	± 10%	38,4	52,8
1060	60	2 700	± 10%	48,0	66,0
1110	110	9 200	± 10%	88,0	121,0
1120	120	11 000	± 10%	96,0	132,0
1220	220	37 000	± 10%	176,0	242,0

The data in bold type pertain to the standard versions of the relays.

Coil data - DC voltage version, reinforced
Table 2

Coil code ⑥	Rated voltage V DC	Coil resistance at 20 °C Ω	Acceptable resistance	Coil operating range V DC	
				min. (at 20 °C)	max. (at 55 °C)
W012	12	85	± 10%	9,6	13,2
W024	24	345	± 10%	19,2	26,4
W048	48	1 370	± 10%	38,4	52,8
W110	110	7 300	± 10%	88,0	121,0
W220	220	30 000	± 10%	176,0	242,0

⑥ For version with contact gap ≥ 3 mm.

Coil data - AC 50/60 Hz voltage version
Table 3

Coil code	Rated voltage V AC	Coil resistance at 20 °C Ω	Acceptable resistance	Coil operating range V AC	
				min. (at 20 °C)	max. (at 55 °C)
5006	6	4,3	± 10%	4,8	6,6
5012	12	18,5	± 10%	9,6	13,2
5024	24	75	± 10%	19,2	26,4
5115	115	1 840	± 10%	92,0	126,5
5120	120	1 910	± 10%	96,0	132,0
5220	220	6 980	± 10%	176,0	242,0
5230	230	7 080	± 10%	184,0	253,0
5240	240	7 760	± 10%	192,0	264,0

Coil data - AC 50 Hz voltage version
Table 4

Coil code	Rated voltage V AC	Coil resistance at 20 °C Ω	Acceptable resistance	Coil operating range V AC	
				min. (at 20 °C)	max. (at 55 °C)
3400	400	21 500	± 10%	320,0	440,0

Electrical life at AC resistive load.
Switching frequency: 1 200 cycles/hour

Fig. 1

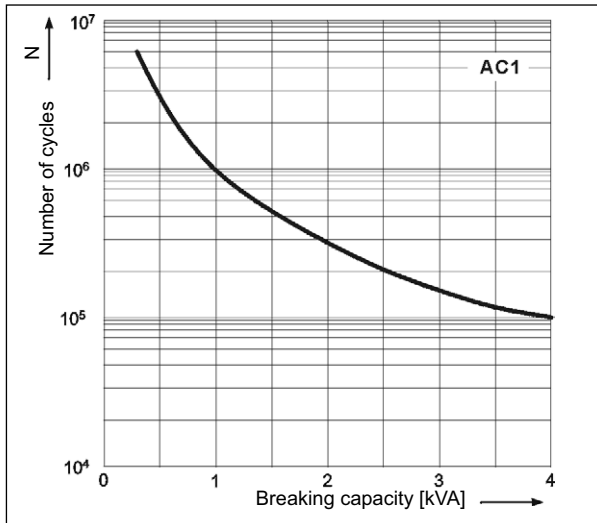

Electrical life reduction factor at AC inductive load

Fig. 2

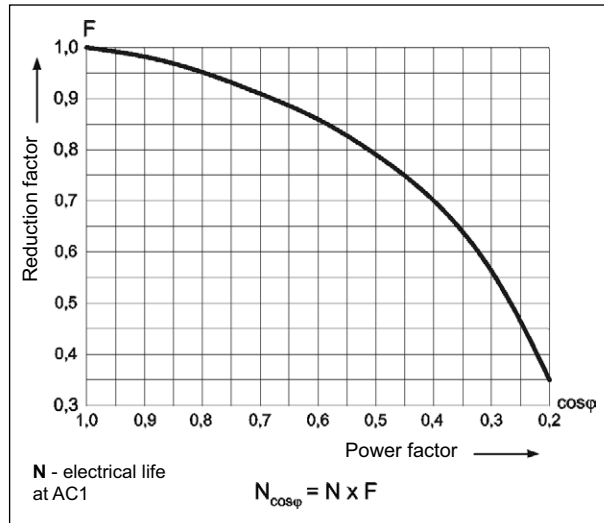

Max. DC breaking capacity
A - resistive load DC1
B - inductive load L/R = 40 ms

Fig. 3

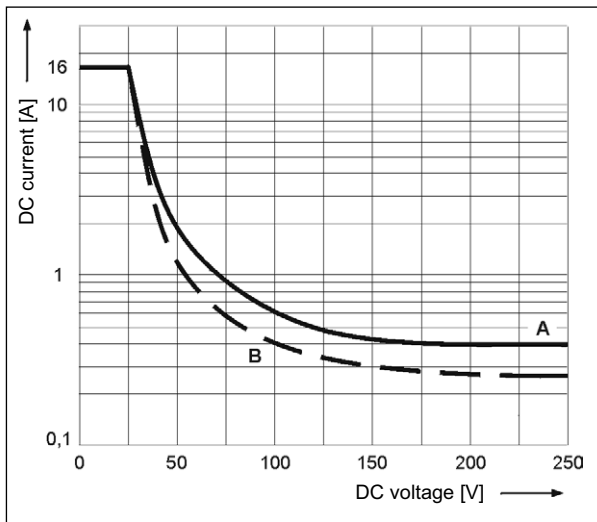

Connection diagrams (pin side view)

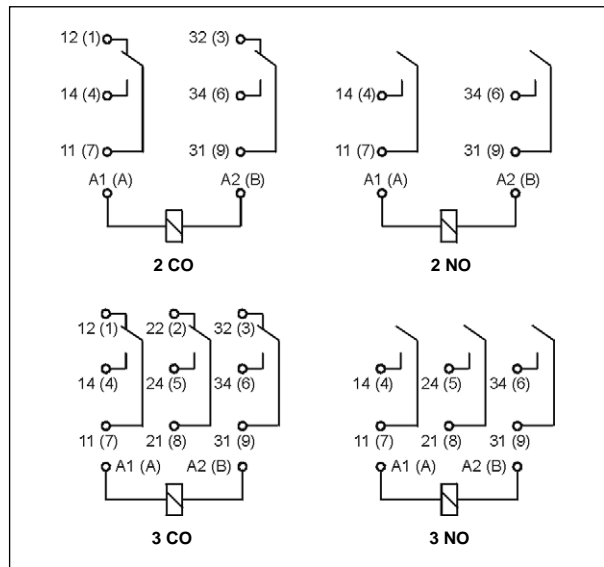

Dimensions - RUC faston 4,8 x 0,5
- plug-in version (standard)

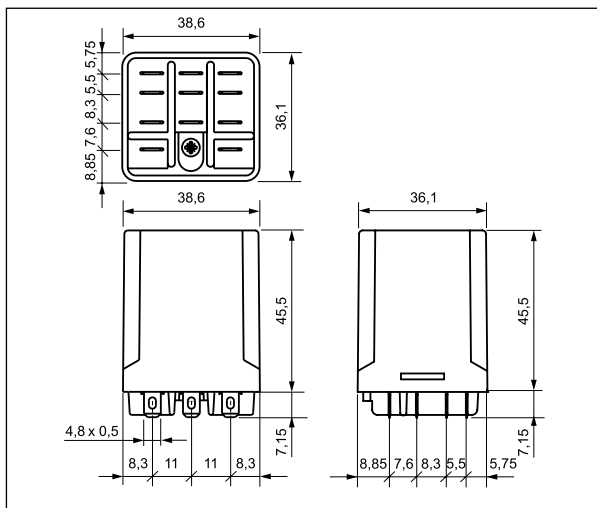

Dimensions - RUC faston 4,8 x 0,5
- PCB version

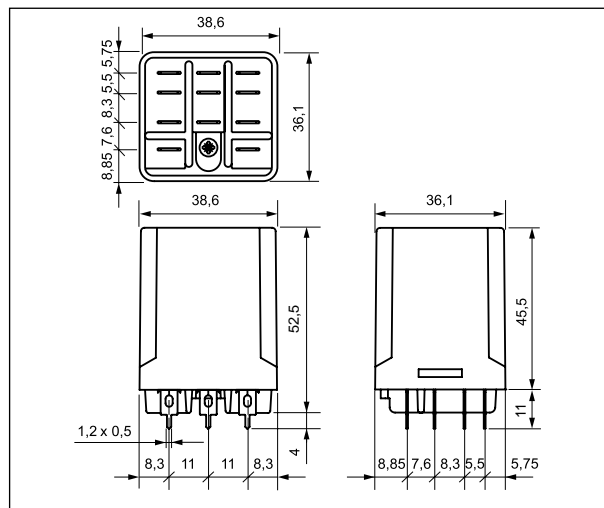

RUC

industrial relays of small dimensions

Dimensions - RUC faston 4,8 x 0,5
- version with vertical adaptor (V)

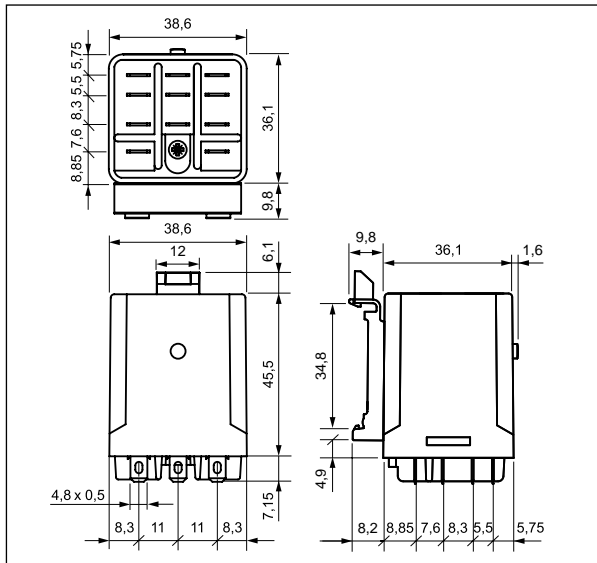

Dimensions - RUC faston 4,8 x 0,5
- version with horizontal adaptor (H)

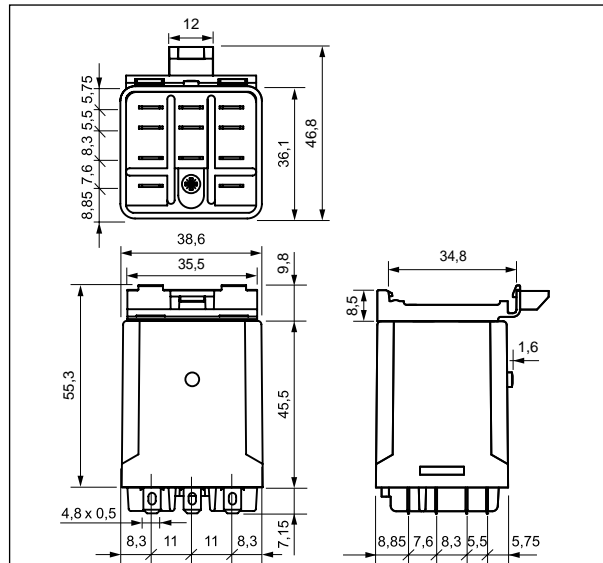

Dimensions - RUC faston 6,3 x 0,8
- version with vertical adaptor (V)

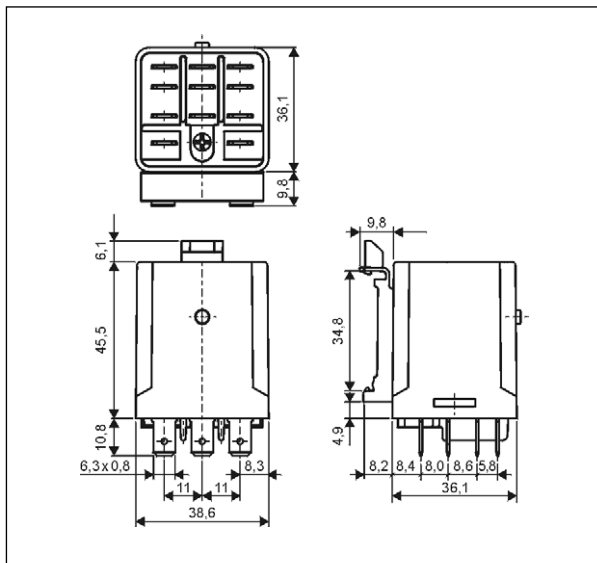

Dimensions - RUC faston 6,3 x 0,8
- version with horizontal adaptor (H)

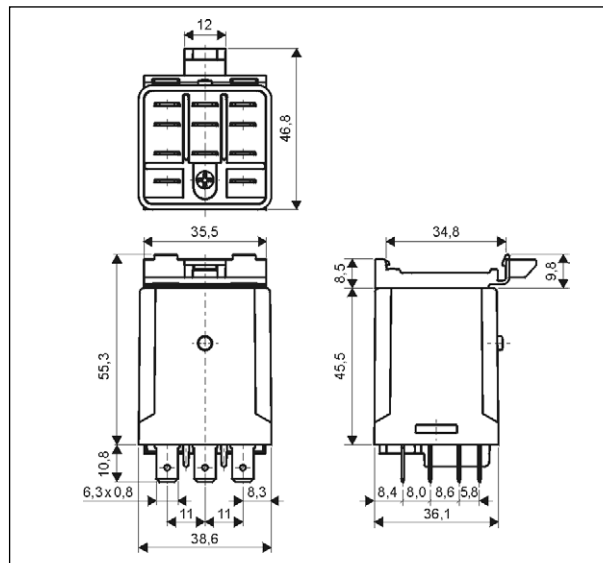

Dimensions - RUC faston 4,8 x 0,5 (faston 6,3 x 0,8)
- version with mounting flange in the wall of the cover

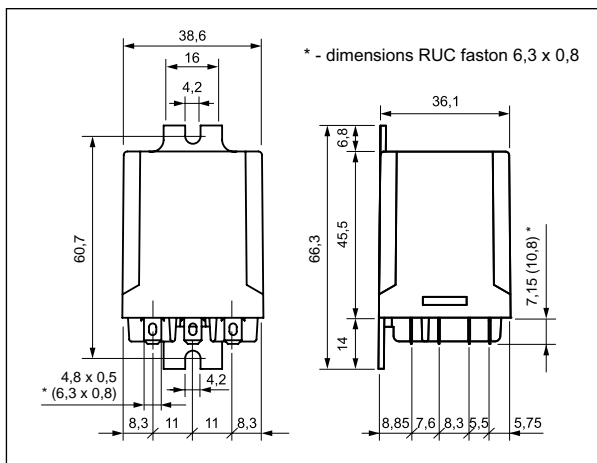

Mounting

Relays RUC are offered in versions:

- standard, for screw terminals plug-in sockets **GUC11** with clip **MBA**, 35 mm rail mount acc. to PN-EN 60715 or on panel mounting with two M3 screws
- with mounting flange in the wall of the cover, on panel mounting with two M4 screws, flat insert connectors - faston 187 (4,8 x 0,5 mm) or faston 250 (6,3 x 0,8 mm)
- with vertical (V) or horizontal (H) adaptors for direct mounting on 35 mm rail mount acc. to PN-EN 60715, flat insert connectors - faston 187 (4,8 x 0,5 mm) or faston 250 (6,3 x 0,8 mm)
- for direct PCB mounting

⚠ Relays unavailable with (V) or (H) adaptor, and cover with mounting flange.

⚠ For RUC faston 4,8 x 0,5 with GUC11 socket, max. switching voltages and coil voltages of relays are limited to 250 V AC / DC.

Ordering codes

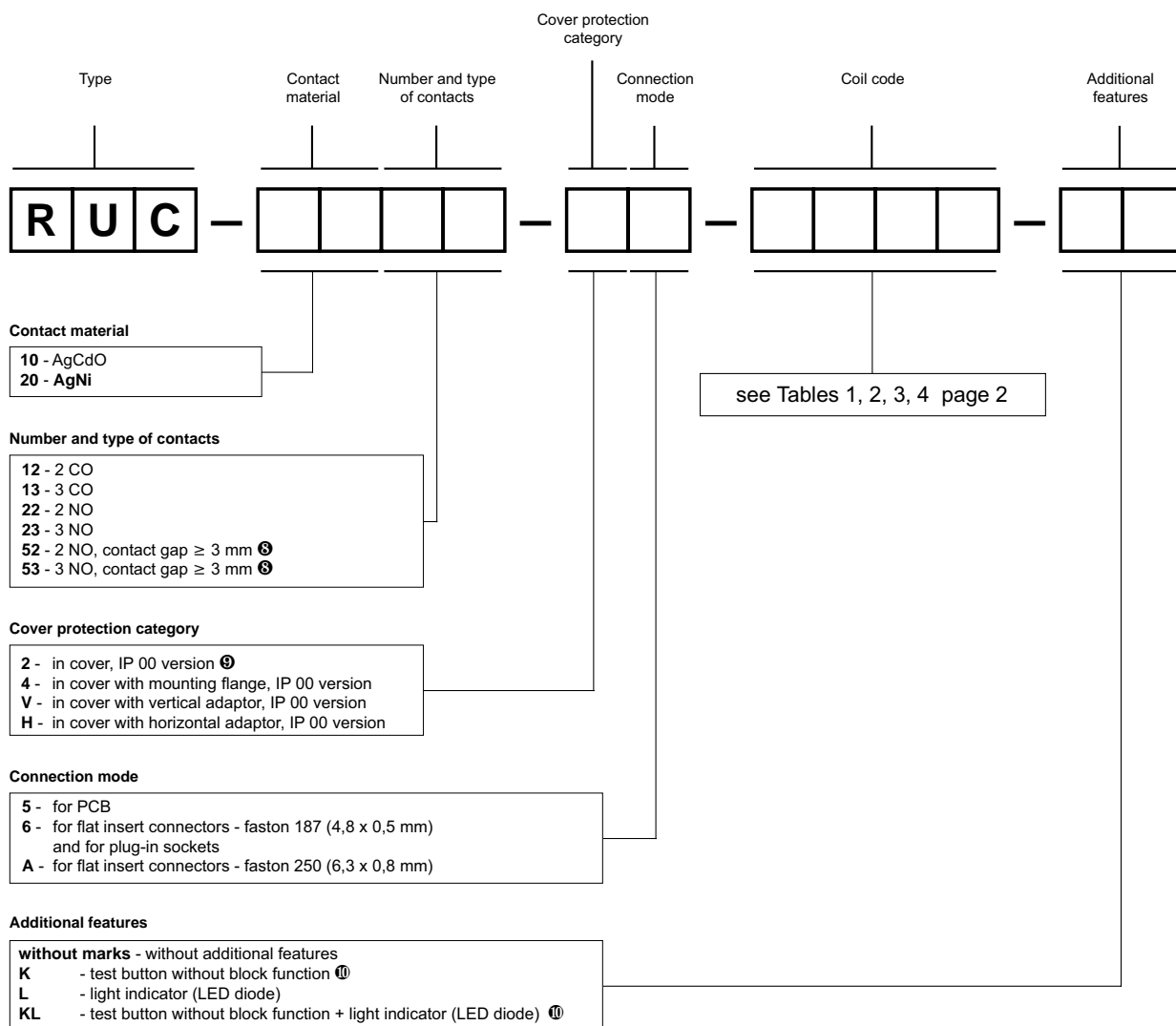

③ For versions with reinforced DC coils: W012, W024, W048, W110, W220 and with AC coils.

④ Only for version RUC faston 4,8 x 0,5.

⑥ Additional features is not available in versions of relays with contact gap ≥ 3 mm.

Examples of ordering codes:

RUC-2053-26-W024 relay **RUC**, faston 187 (4,8 x 0,5 mm), with contact gap ≥ 3 mm, for plug-in sockets GUC11, three normally open contacts, contact material AgNi, reinforced coil voltage 24 V DC, in cover IP 00

RUC-2013-V6-3400-KL relay **RUC**, faston 187 (4,8 x 0,5 mm), for flat insert connectors, with vertical adaptor (V), three changeover contacts, contact material AgNi, coil voltage 400 V AC 50 Hz, with test button without block function and light indicator (LED diode), in cover IP 00

RUC-2052-HA-W220-L relay **RUC**, faston 250 (6,3 x 0,8 mm), for flat insert connectors, with contact gap ≥ 3 mm, with horizontal adaptor (H), two normally open contacts, contact material AgNi, reinforced coil voltage 220 V DC, with light indicator (LED diode), in cover IP 00

RUC-1022-25-5024 relay **RUC**, for PCB, two normally open contacts, contact material AgCdO, coil voltage 24 V AC 50/60 Hz, in cover IP 00

Plug-in sockets and accessories

GUC11

For RUC faston 4,8x0,5, RUC-M

Screw terminals
 Max. tightening moment
 for the terminal: 0,7 Nm
 35 mm rail mount
 acc. to PN-EN 60715
 or on panel mounting
 82 x 42,2 x 26,5 mm
 Three poles
 16 A, 250 V AC



Connection diagram

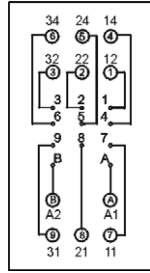

Accessories

MBA

Dimensions

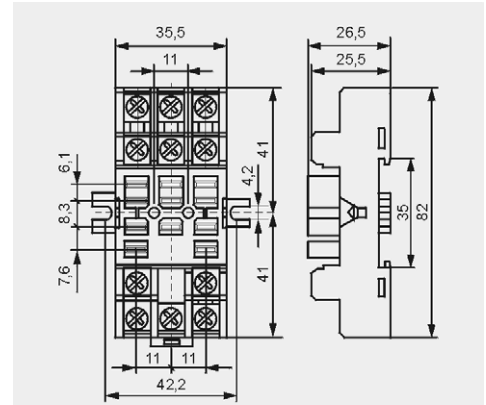

 For RUC faston 4,8 x 0,5 and RUC-M, with GUC11 socket, max. switching voltages and coil voltages of relays are limited to 250 V AC / DC.

PRECAUTIONS:

1. Ensure that the parameters of the product described in its specification provide a safety margin for the appropriate operation of the device or system and never use the product in circumstances which exceed the parameters of the product. 2. Never touch any live parts of the device. 3. Ensure that the product has been connected correctly. An incorrect connection may cause malfunction, excessive heating or risk of fire. 4. In case of any risk of any serious material loss or death or injuries of humans or animals, the devices or systems shall be designed so to equip them with double safety system to guarantee their reliable operation.